

Media Converters: LAN to MAN and Beyond

Media Conversion

100 Mbps

10 Mbps



Desktop

Central Office



100 Mbps

10/100/1000 Mbps Backbone



Business

Table of Contents

Introduction	1
Media Conversion in the Local Area Network	1
Converter Types	1
Connecting Different Media Types in the LAN	2
Connecting Different Media and Speeds in the LAN	2
Media Converters and Fiber Backbone	3
Fiber-to-the-Desktop	4
Bridging Two LANs over Fiber	4
New Single Strand Fiber Applications	5
Benefits of Media Conversion in the LAN	5
Media Converters in the MAN and Beyond	6
Optical Ethernet	6
Provisioning Optical Circuits	7
Media Converters are Flexible	7
Need for Management	8
Benefits of Optical Ethernet and Media Converters in the MAN	9
Conclusion	9
Appendix	10

We are here to help! If you have any questions about your application, our products or this white paper, please contact us at sales@imcnetworks.com



Networks

Introduction

Media converters play an important role in today's multi-protocol, mixed media Local Area Networks. For example, LAN administrators can deploy media converters to integrate fiber optic cabling and active equipment into existing copper-based, structured cabling systems while achieving significant cost-savings.

Media converters are also a critical piece of the data networks outside the LAN, as electrical-to-optical conversion technology is enabling service providers to speed up the deployment and minimize the cost of provisioning Fiber-to-the-Subscriber, and offering MAN access and data transport services to enterprise customers. We will discuss the benefits of Ethernet as an end-to-end transport protocol, and illustrate how media converters are lighting up the first mile, enabling tier 1 carriers, MSOs, CLECs and "EtherLECs" to offer their customers a transparent WAN interface.

Media Conversion in the Local Area Network

Introduced to the industry over a decade ago, media converters are simple networking devices that make it possible to connect two dissimilar media types such as twisted pair with fiber optic cabling.

Converter types

Today's converters support many different data communication protocols including Ethernet, Fast Ethernet, Gigabit Ethernet, T1/E1, DS3/E3, as well as multiple cabling types such as twisted pair, multi-mode and single-mode fiber and single-strand fiber optics. Media converter types range from small standalone devices to PC card based converters to high port-density chassis systems that offer many advanced features for network management. Simple Network Management Protocol (SNMP) enables proactive management of link status, monitoring chassis environmental statistics and sending traps to network managers in the event of a fiber break or even link loss on the copper port. The ability to quickly identify and isolate problems allows LAN administrators to maximize network uptime.

Chassis systems provide unparalleled flexibility and allow for mixing of slide-in converters as required. For example, when combined with a 10/100/1000 Ethernet switch, LAN administrators can use modular converters to satisfy a wide range of requirements in network connectivity and distance. Modular converters can be installed to convert copper switch ports to multi-mode or single-mode fiber as needed.

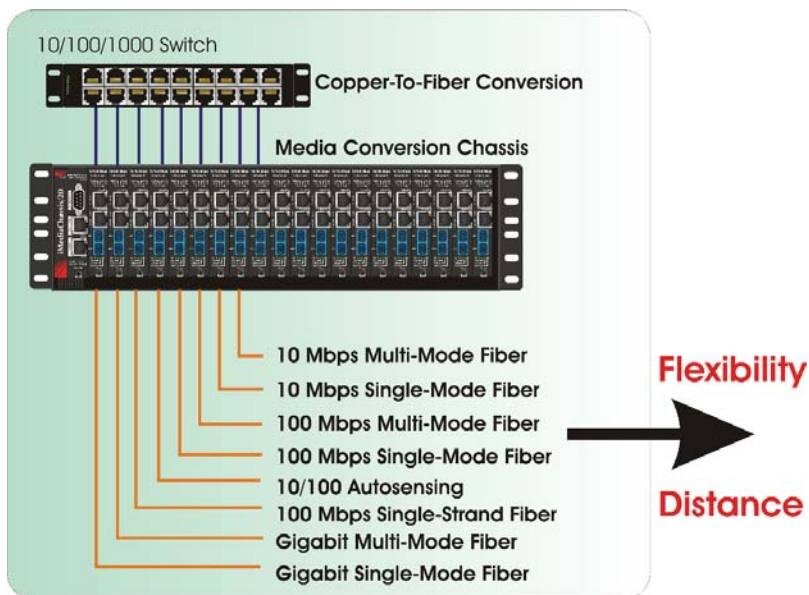

Figure 1: A modular chassis system can accommodate up to 20 managed conversions. Slide-in converters provide unparalleled flexibility for combining media types and distance.

Connecting Different Media Types in the LAN

With the forecasted growth of today's organizations, administrators must accommodate the continuing growth in data traffic and the increasing demand for bandwidth, while leveraging the investment in the existing network infrastructure. Instead of costly "forklift upgrades" and rewiring for fiber, media converters can extend the productive life of the existing structured cabling as well as the active equipment. Media converters can be used anywhere in the network to integrate fiber with the existing copper wiring and equipment to support new applications, technologies and future growth.

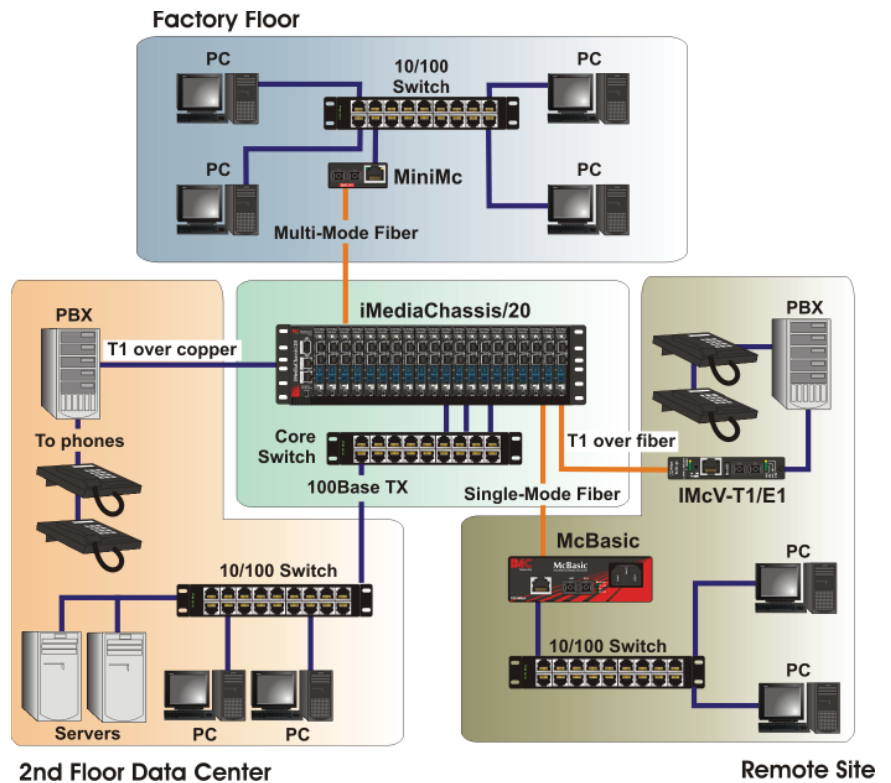

Figure 2: Media converters can be used in a LAN to extend the productive life of the legacy wiring plant by connecting it to new devices with fiber optic media interfaces.

When connecting legacy 10Base-T network segments to a newer 100Base-Tx or 100Base-Fx Fast Ethernet infrastructure, switching media converters are the perfect solution. Switching media converters feature a 10/100 Auto Negotiating copper port and a Fast Ethernet fiber port. For example, existing Half-Duplex hubs can be connected to 100Base-Tx Fast Ethernet network segments over 100Base-Fx fiber.

Connecting Different Media and Speeds in the LAN

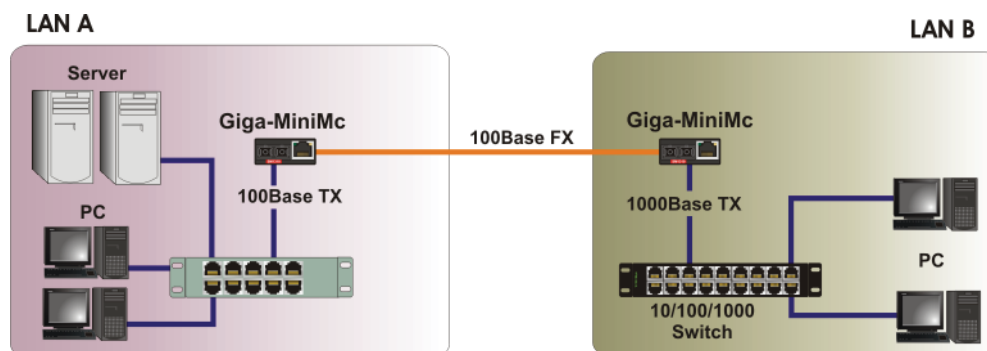

Figure 3: Switching media converters are unique in their ability to connect dissimilar speed and media, as highlighted in this application.

Media Converters and Fiber Backbone

Today, a large percentage of structured LAN wiring is twisted pair with a distance limitation of 100 meters, or about 300 feet. While fiber is becoming increasingly less expensive, copper-based hardware still makes up the majority of existing networks. In the telecommunications room, network managers can deploy a core switch with 100Base-Tx or Gigabit Ethernet copper ports, which is more economical than fixed fiber ports. Media converters can be used to convert in the telecommunications room and again at the workgroup switch to interconnect the fiber backbone.

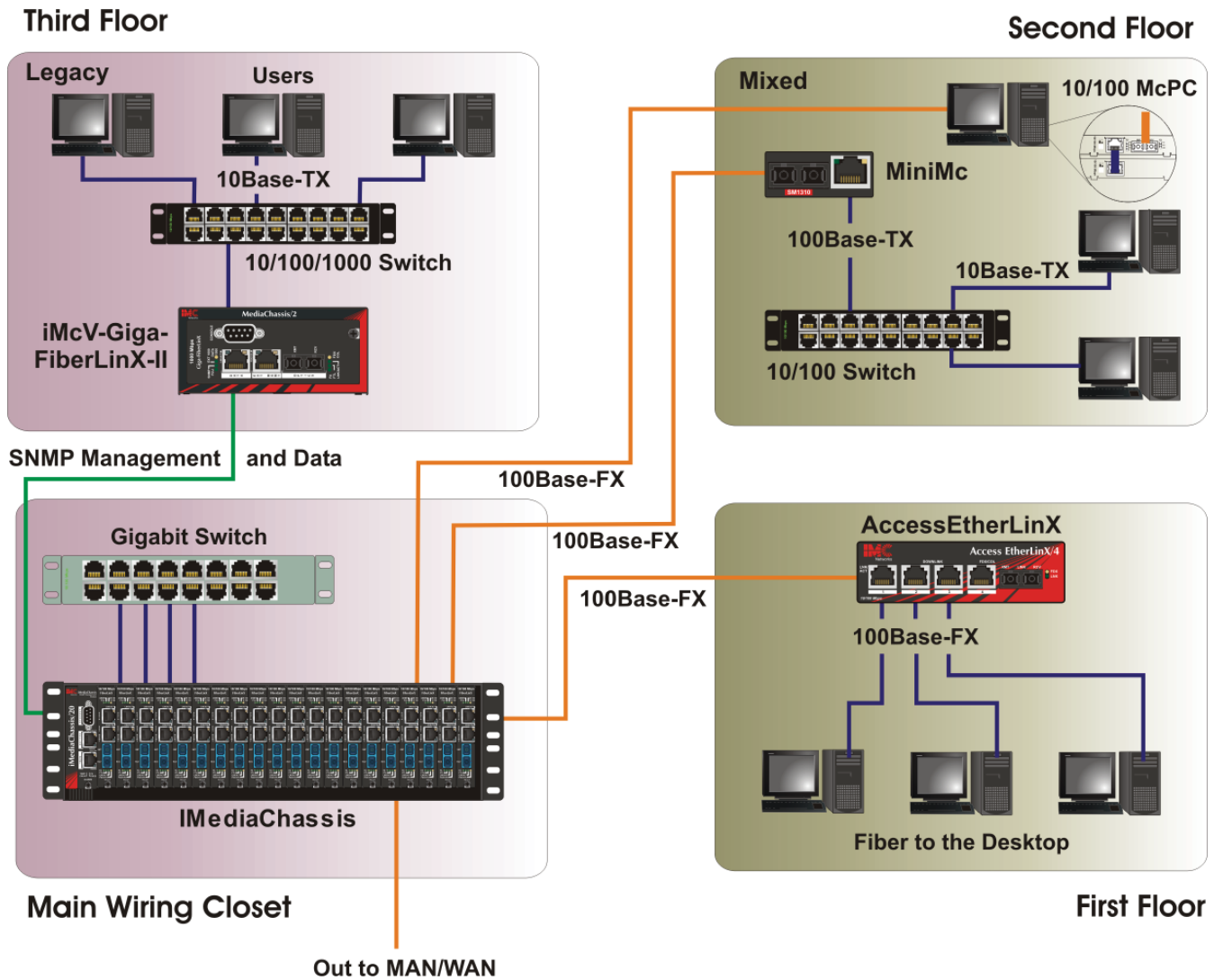

Figure 4: Media converters are a perfect combination with a 100Base-SX or 1000Base-SX multi-mode fiber backbone. Use them to connect workgroups in copper-based wiring segments, or extend the reach of a fiber backbone with fiber mode converters up to 130 kilometers.

Fiber to the Desktop (FTTD)

Already established in the LAN backbone at 100 Mbps and Gigabit speeds, fiber is making further headway to accommodate high-bandwidth applications such as streaming media and Voice over IP for more secure desktop connections. Media converters are finding new use in the LAN by making FTTD cost-effective. Instead of expensive fiber home runs requiring all-fiber switches, patch panels and Network Interface Cards, organizations can reap the benefits of media converters and save money by converting in the telecommunications room and again at the desktop.

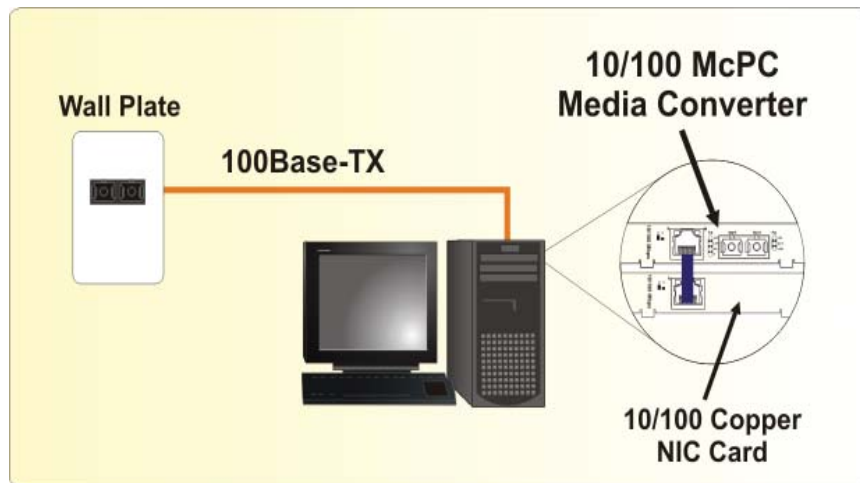

Figure 5: Media converters make FTTD a reality. Standalone or PC card media converters can be used at the desktop with standard 10/100 NICs to achieve further cost savings.

Bridging Two LANs over Fiber

When expanding the reach of the LAN to span multiple locations, media converters are useful in connecting multiple LANs to form one large "campus area network" that spans over a limited geographic area. As premises networks are primarily copper-based, media converters can extend the reach of the LAN over single-mode fiber up to 130 kilometers with 1550nm optics.

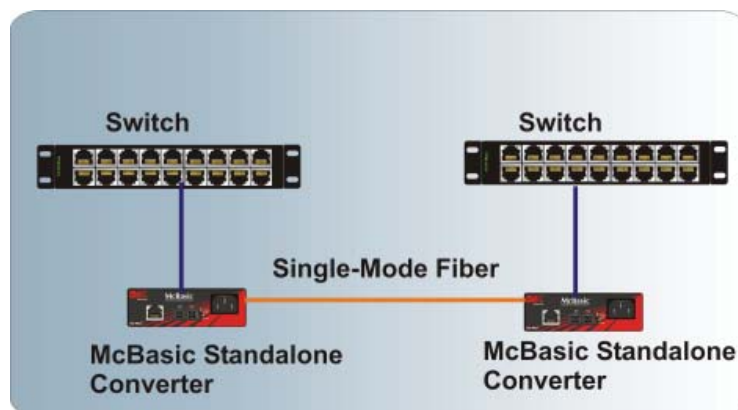

Figure 6: Connect two distant switches using single-mode fiber and two media converters.

New Single-Strand Fiber Applications

The exponential growth of data traffic has turned the spotlight on Wavelength Division Multiplexing (WDM) technology. WDM is simply multiplexing two wavelengths on a single-strand of fiber in order to increase the transport capacity of optical fiber, and then de-multiplexing the data at the other end. While mostly associated with carrier backbone applications, WDM in the LAN is especially beneficial in situations where fiber is in limited supply or expensive to provision. Single-strand fiber converters convert copper to fiber, but utilize only one strand of fiber, instead of two, to extend full-duplex data transmission up to 70 kilometers.

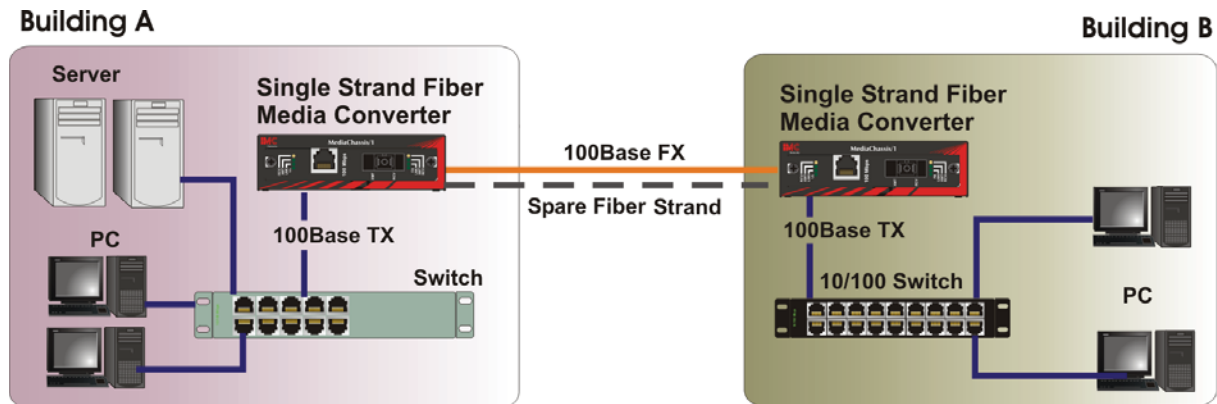

Figure 7: Single-strand fiber media converters using WDM technology can effectively double fiber capacity by combining wavelengths onto one strand of fiber. The spare fiber strand can immediately double the data traffic or be saved for future use.

Benefits of Media Conversion in the LAN

Reduces the overall networking cost when used with more cost-effective switches with multiple, fixed, RJ-45 copper ports instead of fiber ports. Network managers can convert only the selected copper ports for multi-mode or single-mode fiber as needed.

Protects the existing investment in the network. As physical layer devices, media converters can easily be located or relocated to other areas within the installation, further leveraging the original investment.

Extends the productive life of the legacy wiring plants of companies and organizations. It also keeps pace with evolving technology standards by being able to interconnect different devices supporting various media interfaces, whether it is twisted pair, single-mode or multi-mode fiber.

Provides a gradual migration path from copper to fiber, as well as from 10 Mbps Ethernet to 100 Mbps Fast Ethernet to Gigabit Ethernet. By adding a fiber segment into copper networks, network managers can also easily increase cabling distances and reduce electromagnetic interference.

Offers the flexibility of combining copper with 850 nm and 1300 nm multi-mode fiber and 1310 nm and 1550 nm single-mode fiber; slide-in media conversion modules for all cable types can reside in one media conversion chassis.

Eases network troubleshooting and minimizes down-time. For example, if one slide-in converter goes down, only that connection is effected. If a fixed port fiber switch goes down, as many as 24 connections are down simultaneously, when repairing the faulty port.

Media Converters in the MAN and Beyond

Most Local Area Networks have migrated to a Gigabit or at least a Fast Ethernet backbone with switched 10/100 connections to clients, printers and file servers. Fast on the inside, but slow on the outside, many U. S. businesses rely on copper T-1 and T-3 connections, or fiber ATM / SONET circuits for WAN connectivity. These connections were designed for voice but were never intended to handle the exponentially growth of Internet and data traffic, applications or the protocols typically used in today's LAN. What's more, provisioning and maintaining these circuits, or upgrading from a T-1 to a T-3 connection is an expensive and time-consuming proposition for both the service provider and the customer. It also requires significant capital investment at both the Point of Presence (POP) and the customer premises.

Ethernet is the dominant LAN protocol with the highest market penetration. Ethernet equipment is readily available at reasonable prices, and provides a migration path from 10 Mbps to 100 Mbps to Gigabit Ethernet. And with the 10, 40 and eventually, 100 Gigabit Ethernet standard, the application space for Ethernet will logically expand from the LAN to the MAN, and eventually to the WAN.

Optical Ethernet

Optical Ethernet — i.e. transmitting Ethernet packets over optical fiber — is nothing new in private networks. LAN and enterprise campus network administrators have used Ethernet over optical fiber media for years to overcome the distance limitation of 100 m / 330 ft. when using copper-based cabling. By converting to fiber, distances up to 130 km are easily achieved with 1550 nm optics. Using media converters at both ends, LAN and campus network managers can build their own private MANs that tie all the buildings, and even remote locations, into one broadcast domain.

On the public network side, Optical Ethernet has become an increasingly attractive option for high-speed Internet access and for MAN transport in recent years. The fundamental reason why Ethernet has emerged as a competitor to legacy ATM/SONET services is cost. Simplifying the network design and utilizing low cost Ethernet as an end-to-end LAN/MAN/WAN protocol is a win-win situation for both the service provider and the customer. This is how Ethernet won the LAN years ago; it was not necessarily the best technology, it was the most cost-effective and easily implemented.

Ethernet is also extremely efficient. Designed for data transport, it is well suited for Internet Protocol (IP), which is the fastest growing traffic type. SONET, for example, is based on Time Division Multiplexing, which is good for voice but does not adapt well to bursty IP traffic.

Major advantages of Optical Ethernet include its scalability, ability to prioritize packets and the ease of throttling customer link speeds. While some Competitive Local Exchange Carriers (CLEC) offer either 10 Mbps or 100 Mbps for a flat fee, typically Layer 3 rate limiting is implemented at the POP switch to enable customers to purchase the bandwidth they need, when they need it. As requirements change, customers can subscribe to more bandwidth, and get it within days instead of waiting for weeks to have their Telco circuits upgraded. In some cases, customers can upgrade to a bigger pipe themselves by using the service provider software interface.

Today's metro switches can limit bandwidth in 1 Mbps increments, although some access equipment features even finer granularity and can throttle ingress/egress data throughput in 1 Kbps increments all the way up to 1 Gbps. Ease of bandwidth control and fine granularity also enables new Ethernet-based services networks to attract and retain customers who realize the value of using and paying for the bandwidth as needed.

Provisioning Optical Circuits

Whereas residential FTTH deployments typically utilize Point-to-Multipoint distribution via Passive Optical Networking for cost reasons, the network architecture in providing service to business customers is primarily Point-to-Point.

Media converters are deployed in the MAN to provide the physical layer connection and to bridge the bandwidth gap that exists between the LAN and MAN. While structured cabling in the LAN is typically either twisted pair copper or multi-mode fiber, single-mode fiber is typically used in the MAN. The best design is to utilize media converters at both ends of the first mile to provide the electrical-to-optical conversion from the POP switching router to single mode fiber, and back to 10/100/1000Base-T Ethernet at the customer premises.

This network design sets a standard for cost-effectiveness. By populating the POP switch with standard 10/100 copper blades instead of long haul fiber blades, service providers can save thousands of dollars in capital equipment.

Figure 8: By using chassis based 10/100 autosensing media converters at the Point of Presence, the service provider can provision a 10 Mbps or 100 Mbps dedicated connection with the existing equipment since the converters provide an upgrade path between the two speeds. As customer needs increase, the bit rate can be increased to 100 Mbps through the POP switch and the converter will automatically adapt to the increased speed, eliminating a visit to the customer site or POP.

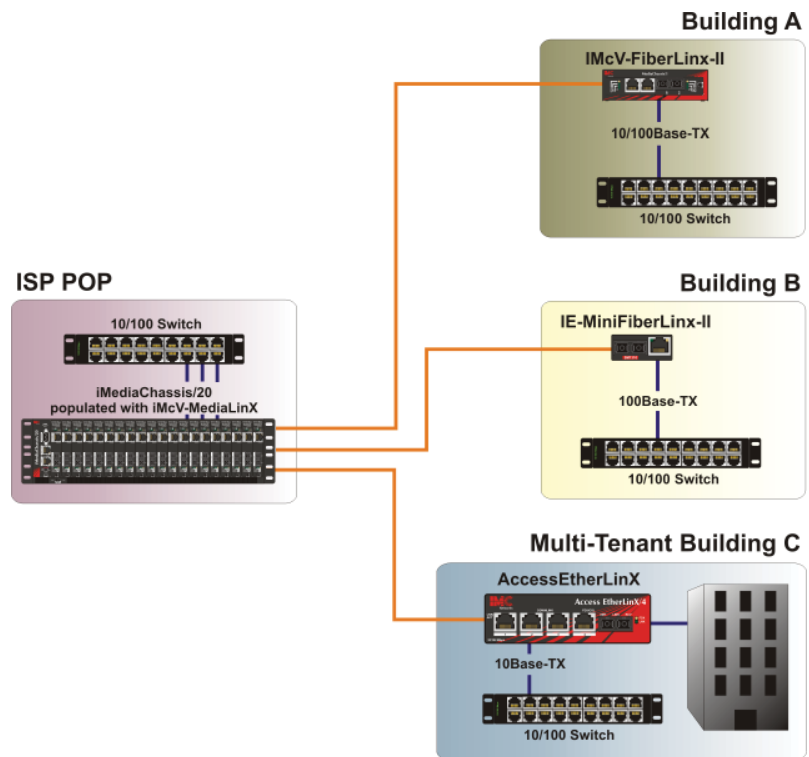

Media Converters are Flexible

Connecting copper switch ports to modular media converters for optical access enables service providers to fully benefit from the flexibility and distance offered by media converters. Media converters support multiple types of media from copper to multi-mode and single-mode fiber, and support 10 Mbps, 100 Mbps and Gigabit Ethernet. Single-mode converters routinely cover distances of 20, 40 and 80 kilometers with 1310 nm optics, and even up to 130 kilometers with 1550 nm optics.

Media converters can also greatly enhance the consistency of service. With modular media converters, the network administrator can troubleshoot one circuit while the other customers' connections remain up and running. On the customer side, a standalone media converter can be used to provision an optical demarcation point, resulting in more cost savings and simplicity because the Telco router can be eliminated. Behind the media converter on the network edge, a Layer 2 LAN switch can be used to interconnect the public and private networks. Advanced protocols such as 802.1q, 802.1p, Quality of Service, and Network Address Translation can be handled at the POP switching router.

Need for Management

The ability to manage and monitor media conversions is becoming increasingly important in service provider and outside plant applications. Using managed media conversion, fiber network operators can easily provision service and also minimize network downtime by quickly isolating problems; visits to remote sites are greatly reduced since SNMP management shows exactly where faults reside. To help diagnose problems such as a link loss situation or the loss of one strand of fiber, media converters offer features that continually monitor system integrity and thus, decrease troubleshooting efforts.

Service providers have to be able to proactively manage the circuit to ensure quality and consistency of service, even though they don't own the remote network, and don't have access to the customer LAN located miles away. When provisioning dedicated, high-speed data connections between two locations, service providers need to be able to monitor BOTH end-points as a single SNMP management entity instead of two separate locations. This can be achieved by deploying an optical converter/demarcation unit, such as IMC Networks' *iMcV-FiberLinX-II*. Installed at the customer LAN edge, the *iMcV-FiberLinX-II* can be managed through the fiber uplink port with in-band SNMP that is separate and completely transparent to customer data traffic and other protocols. Remotely managed customer premises equipment such as the *iMcV-FiberLinX-II* can alert the service provider to any problems on the long-haul fiber run, provide data traffic statistics and vital information on the unit and link conditions at the remote site without rolling a truck to the customer site.

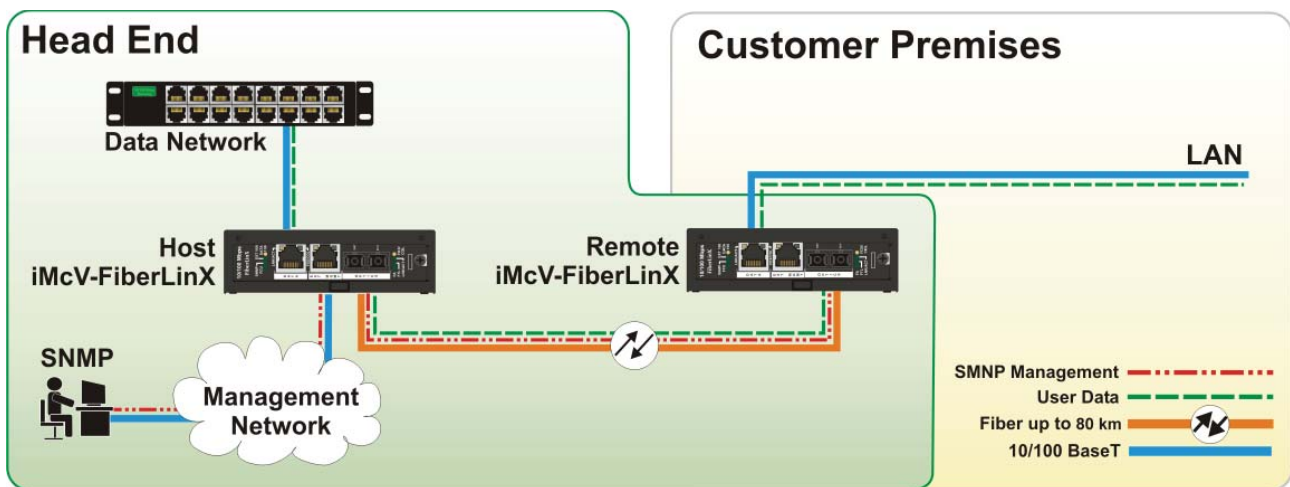

Figure 9: IMC Networks' *iMcV-FiberLinX-II* with In-Band Simple Network Management Protocol can be used to ensure fiber link and data integrity between two physical locations. SNMP and data traffic share the 100 Mbps Full Duplex fiber, but SNMP traffic is isolated and remains transparent to the customers' traffic.

Benefits of Optical Ethernet and Media Converters in the MAN

Tried and proven in the LAN, Ethernet is well positioned to become the protocol of choice for the transport of data, voice and video also outside the LAN.

Protocol transparency — service provider supplies the customer a standard Ethernet interface

Bit rate transparency — customer can connect to the service provider network at 10 Mbps, 100 Mbps or Gigabit Ethernet

Ethernet simplifies the network design — a traditional Telco router can be replaced with a remotely managed media converter

Optical Ethernet services often work with customer's own IP addressing scheme

Customers can use the bandwidth they need, when they need it, without the wait associated with legacy services

Using media converters with Ethernet-based services minimizes the cost of provisioning and maintaining optical circuits

Conclusion

Fiber optics is the only media that can support a virtually limitless bandwidth and can break the bottleneck that still exists between the customer premises and the service provider point of presence. The demand for fiber connections continues to grow parallel with the continuing demand for more bandwidth and introduction of new applications.

Where customers have access to carrier dark fiber, Optical Ethernet makes sense because of low cost, simplicity and scalability. Bit-for-bit, Ethernet is the undisputed heavyweight champion of the high-speed IP and metro access services. With new evolving standards, Ethernet is also destined to become the dominant protocol outside the LAN in the MAN access and long-haul WAN market spaces.

Tried and proven in the LAN, media converters are now lighting up the first mile with optical Ethernet services. The bottom line is that media converters make practical sense in both LAN and MAN applications. Simple and robust in design yet cost-effective to deploy, media converters are the best solution for the optical demarcation between the LAN and MAN and bridging the bandwidth gap that exists between the Local Area Network and service provider fiber optic backbone.

About IMC Networks

Since 1988, IMC Networks is a leading manufacturer of optical access, FTTx and media conversion solutions for Enterprise, government and service providers, delivering 21 years of excellence in product quality, customer satisfaction and value. IMC Networks is ISO 9001:2000 registered; all products are RoHS and EU REACH compliant, Made in the USA and carry a comprehensive 6 year warranty.

Fiber Consulting Services



IMC Networks' Fiber Consulting Services (FCS) offers free consulting assistance to network managers and system integrators with the design and development of their fiber-based networks. Contact us at fcs@imcnetworks.com or by calling 1-800-624-1070 in the USA or +1-949-465-3000 outside of the USA.

MEDIA CONVERTERS

<p>Convert From: 10 Mbps Twisted Pair Copper 10Base-T</p>	<p>Convert To: 10 Mbps Fiber 10Base-FL 850 nm MM 2 kilometers 10Base-FL 1300 nm MM 2 kilometers 10Base-FL 1310 nm SM 40 kilometers 10Base-FL 1310 nm SM 80 kilometers 10Base-FL 1550 nm SM 80 kilometer</p>
<p>Convert From: 100 Mbps Twisted Pair Copper 100Base-TX Twisted Pair</p>	<p>Convert To: 100 Mbps Fiber 100Base-SX 850 nm MM 2 kilometers 100Base-FX 1300 nm MM 2 kilometers 100Base-FX 1310 nm SM 40 kilometers 100Base-FX 1310 nm SM 80 kilometers 100Base-FX 1550 nm SM 80 kilometers</p>
<p>Convert From: 1250 Mbps Twisted Pair Copper 1000Base-T</p>	<p>Convert To: 1250 Mbps Fiber 1000Base-SX 850 nm MM 550 meters 1000Base-LX 1310 nm SM 15 kilometers 1000Base-LX 1310 nm SM 40 kilometers 1000Base-LX 1550 nm SM 70 kilometers</p>

MODE CONVERTERS

<p>Convert From: Protocol-Independent Fiber 850 nm MM fiber</p>	<p>Convert To: Protocol-Independent Fiber 1300 nm MM fiber 1310 nm SM fiber 1550 nm SM fiber</p>
<p>Convert From: Protocol-Independent Fiber 1300 nm MM fiber</p>	<p>Convert To: Protocol-Independent Fiber 1310 nm SM fiber 1550 nm SM fiber</p>
<p>Convert From: Protocol-Independent Fiber 1310 nm MM fiber</p>	<p>Convert To: Protocol-Independent Fiber 1310 nm SM fiber 1550 nm SM fiber</p>
<p>Convert From: Protocol-Independent Fiber SFP</p>	<p>Convert From: Protocol-Independent Fiber SFP</p>

Stand-alone Converters	Modular iMediaChassis System	McPC Card Converters
		
<p>Small, rugged design that features an internal power supply, the <i>McBasic</i> is one of the best stand-alone media converters in the industry.</p>	<p>SNMP manageable chassis systems enable the use of a variety of modular media converters, and the combining of multiple protocols and media types in one rack-mountable chassis.</p>	<p>Deploying Fiber-to-the-Desk is easy with the <i>McPC</i> line of copper to fiber media converters.</p>



www.imcnetworks.com

IMC Networks
Headquarters/Western US
19772 Pauling
Foothill Ranch, CA 92610
TEL: 949-465-3000
FAX: 949-465-3020
sales@imcnetworks.com

IMC Networks
Eastern US/Latin America
18840 U.S. Hwy. 19 North Suite 306
Clearwater, FL 33761
TEL: 727-797-0300
FAX: 727-797-0331
latinsales@imcnetworks.com

IMC Networks
Europe
Herseltsesteenweg 268
B-3200 Aarschot Belgium
TEL: +32-16-550880
FAX: +32-16-550888
eurosales@imcnetworks.com